

I.	Table of contents	
II.	Foreword	3
A.	Notes on this documentation	3
B.	Documentation Issue status	3
C.	Appropriate use	3
III.	Safety	4
A.	Personnel qualification	4
B.	Description of safety symbols.....	4
C.	Special safety instruction	5
IV.	Handling	6
A.	Transport and storage.....	6
B.	Disposal.....	7
C.	Servicing.....	7
D.	Cleaning	7
V.	Product Overview	8
VI.	General.....	9
A.	Introduction	9
B.	Technical data.....	9
C.	Electrical data	10
D.	Control & Interfaces.....	11
E.	Mechanical data	11
F.	Dimensions.....	11
VII.	Properties.....	13
VIII.	Mechanical installation	13
A.	Mounting fixations.....	14
IX.	Installation	15
A.	Input / Output connections	16
1.	XMOT – TE Intercontec 917 receptable	16
2.	XLINE.....	16
3.	XIO 1 – D Sub 15P Female.....	17
4.	XIO 2 - D Sub 15P Male.....	18
5.	XSAFE - D Sub 9P Female	18
6.	Earth connection.....	19
7.	XETH – RJ45 Jack Ethernet Connection (Optional)	20
8.	MAS - Motor air supply monitoring - Pneumatic quick fit OD 4 mm	20

B.	Connection examples	21
1.	Digital outputs on XIO 1 & XIO 2	21
	21
2.	Digital input on XIO 1	21
3.	Analog input on XIO 1	22
4.	Motor temperature sensor on XMOT.....	22
5.	Option – Motor auto parameter detection on XMOT	23
6.	Relay on XSAFE	24
7.	Encoder input on XIO 2	24
8.	Hall sensor inputs on XIO 2.....	25
9.	MAS – Motor Air Supply Monitoring.....	25
10.	Safe torque off SIL 2 PL d on XSAFE.....	26
X.	HMI Control.....	31
A.	Main Page	31
B.	Load Only page	33
C.	Scope page	33
D.	Status page.....	34
E.	Setup Page.....	35
F.	About page.....	39
XI.	Motor start truth table with default settings	40
A.	Minimum wiring with default configuration.....	40
XII.	Error/Warning List – Troubleshooting guide.....	42
XIII.	ADM – Drive Manager Software	43

II. Foreword

A. Notes on this documentation

This description is only intended for the use of trained specialist in control, automation and electrical engineering who are familiar with the applicable national standards.

It is essential that the following notes and explanations are followed when installing and commissioning these components.

The responsible staff must ensure that the application or use of the products described satisfy all the requirements for safety, laws, regulations, guidelines and standards.

Disclaimer

The documentation has been prepared with the best care. The products described are, however, constantly in development.

For that reason the documentation is not in every case checked for consistency with performance data, standards and other characteristics.

If it contains technical or editorial errors, we retain the right to make alteration at any time and without warning.

No claims for the modification of the products that have already been supplied may be made based on the data, diagrams and descriptions in this documentation.

B. Documentation Issue status

Version	Comment
1.0	First Published
1.1	Add Mot. Aut. Param. Select & Mail server
1.2	Details on auto parameter's function and minimum wiring
1.3	Add run-in utility

C. Appropriate use

The motor drives are designed to operate three-phase current high-speed spindle motors or servo motors. The maximum permissible effective motor voltage must be at least equal to the effective mains voltage fed into the drive.

The drives are designed for the installation as component in electrical systems or machines and may be operated only as integrated system or machine components.

The drives may only be operated in enclosed control cabinets in accordance with the conditions described in the “Technical data” section.



Caution – Risk of injury!

Despite all hardware and software protections the electronic equipment is not fail-safe. The machine manufacturer is responsible for ensuring that the connected motors and the machine are brought into a safe state in the event of a fault in the drive system.

III. Safety

A. Personnel qualification

This description is only intended for trained specialist in control, automation, electrical and drive engineering who are familiar with the applicable national standards.

B. Description of safety symbols

	<p>Serious risk of injury! Failure to follow the safety instructions associated with this symbol directly endangers the life and health of persons.</p>
	<p>Caution – Risk of injury! Failure to follow the safety instructions associated with this symbol endangers the life and health of persons.</p>
	<p>Personal injuries! Failure to follow the safety instructions associated with this symbol can be lead to injuries to persons.</p>
	<p>Damage to the environment or devices! Failure to follow the safety instructions associated with this symbol can be lead to damage to the environment or equipment.</p>
	<p>Tip or pointer This symbol indicates information that contributes to better understanding.</p>

C. Special safety instruction



Serious risk of injury through high electrical voltage!

- Never open the drive when it is live. Wait until the DC link capacitors are discharged. The voltage measure between DC+ and DC- terminal (If present) must have fallen below 50V. Opening the device invalidates all warranty and liability claims.
- Negligent, improper handling of the drive and bypassing of the safety devices can lead to personal injury or death through electric shock.
- Ensure that the cable and connector are connected properly and free of breach.
- Disconnect the drive from the mains supply and secure it against reconnection before connecting or disconnecting the pluggable terminals.
- Disconnect the drive from the mains supply and secure it against reconnection before working on electrical part with a voltage > 50V.
- Due to the DC link capacitors, dangerous voltage may persist at the DC link, after disconnecting the drive wait at least 5 minutes.



Serious risk of injury through hot surfaces!

- The surface temperature may exceed 50°C, resulting in a risk of burns.
- Avoid touching the case during or shortly after operation.
- Leave the drive to cool down for at least 15 minutes after it is switched off.
- Use a thermometer to check whether the surface has cooled down sufficiently.



Danger of injury due to uncontrolled movements!

Read and take note of the important information for commissioning each time before commissioning a drive.



Hazard to persons!

- Carefully read this manual before using the drive thoroughly, paying particular attention to the safety instruction. In the event of any uncertainties please notify your sales office immediately and refrain from working on the drive.
- Only trained, qualified electricians with sound knowledge of drive equipment may work on the device.
- During the electrical installation, it is essential to ensure that the correct fuses/protective circuit breakers are used between the mains supply and the drive. Further information can be found in “electrical installation”.
- If a drive is installed in a machine it must not be commissioned until proof of compliance of the machine with the latest version of the EC Machinery directive has been provided. This includes all relevant harmonised standards and regulations required for implementation of this directive in national legislation.



Attention

Hazard to equipment and environment!

- During installation, it is essential to ensure that the specified ventilation clearances and climatic conditions are adhered to. Further information can be found in the “Technical data” and “Mechanical installation”.
- If the drive is operated in contaminated ambient air, the cooling openings must be checked regularly for blockage. These checks should be carried out up to several times per day.
- The drive contains components at risk from electrostatic discharge caused by improper handling:
 - Please ensure you are electrostatically discharged before touching the drive directly.
 - Avoid contact with highly insulating material (synthetic fibres, plastic film etc.).
 - Place the drive on a conductive surface.
 - Do not touch the motor plug or shield during operation of the drive.

IV. Handling

A. Transport and storage

Transport

- Only by qualified personnel
- Only in recyclable original manufacturer’s packaging
- Avoid sharp impacts
- Temperature: -40... +70°C, varying no faster than 20K/hour
- Air Humidity: Relative humidity max. 95%, non-condensing
- The drive contains components at risk from electrostatic discharge caused by improper handling:
 - Please ensure you are electrostatically discharged before touching the drive directly.
 - Avoid contact with highly insulating material (synthetic fibres, Plastic film etc.).
 - Place the drive on a conductive surface
- If the packaging is damaged check the drive and any accessories for visible damage. Inform the transport company and, if necessary, the manufacturer.

Storage

- The devices and its accessories must not be stored outdoors. The storage space must be adequately ventilated and dry.
- The devices must be stored in the recyclable original manufacturer’s packaging.
- The drive contains components at risk from electrostatic discharge caused by improper handling:
 - Please ensure you are electrostatically discharged before touching the drive directly.
 - Avoid contact with highly insulating material (synthetic fibres, plastic film etc.).
 - Place the drive on a conductive surface
- Max stack height 8 cartons

- Storage temperature: -40... +55°C, varying no faster than 20K/hour
- Air Humidity: Relative humidity max. 95%, non-condensing
- Duration of storage:
 - < 5 years: No limitation.
 - >5 years: The dielectric (an oxidation layer with a thickness of approx. 1µm) in the Dc link capacitors degrades over time, and the capacitors lose their forming. Prior to commissioning of the drive the capacitor must be reformed. Release all electrical connections and feed the drive for about 30 minutes with 230VAC single phase at terminal.



Attention

B. Disposal

- Screw connections enable the drives to be dismantled into main components (aluminium heat sink, steel case, PCBs)
- The device should be disposed of by a certified disposal company.
- Metal part can be sent for metal recycling.
- Electronic parts such as circuit boards and terminals must be disposed of in accordance with the national electronics scrap regulations.

C. Servicing

- The device is maintenance-free
- Opening the device invalidates the warranty

D. Cleaning

- Soiled housing: Clean with isopropanol or similar (**Do not immerse or spray!**)
- Contamination inside the device: Cleaning by manufacturer
- Soiled fan guard: Clean with (dry) brush

V. Product Overview

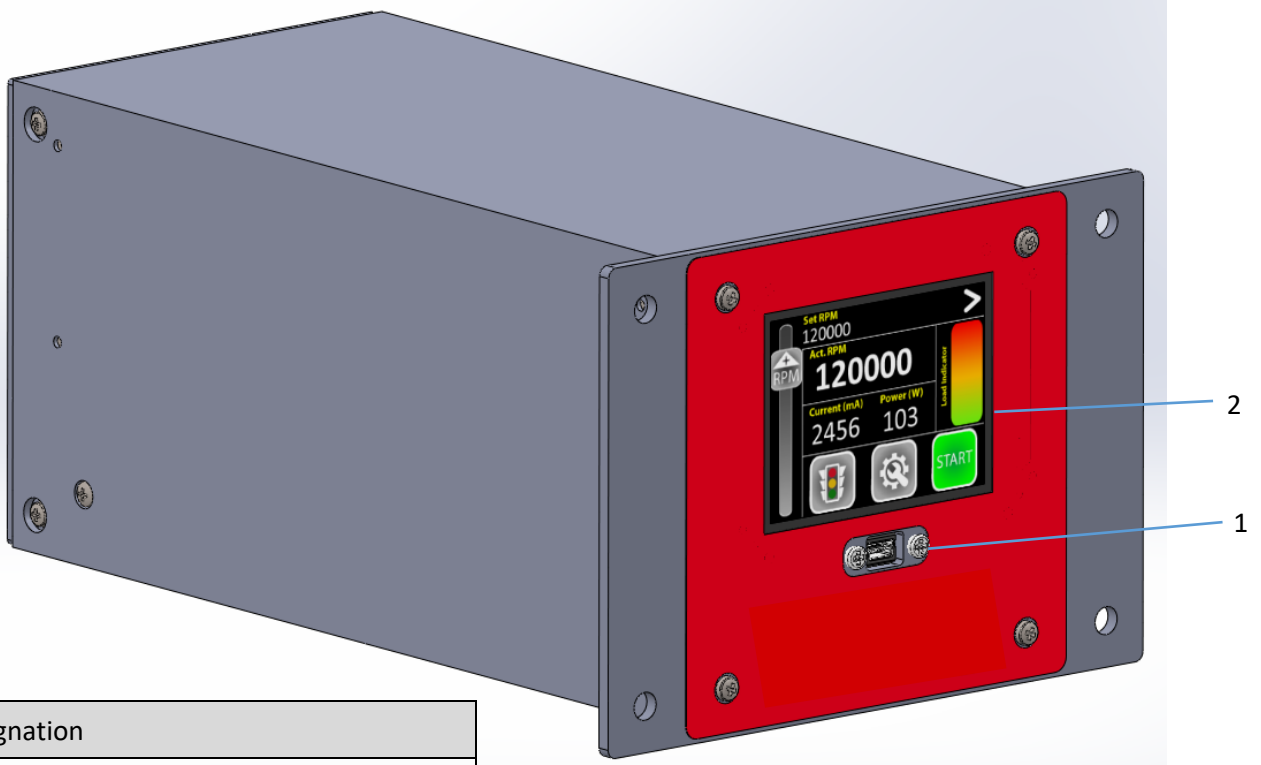

N°	Designation
1	Mini USB connection
2	Touch screen HMI

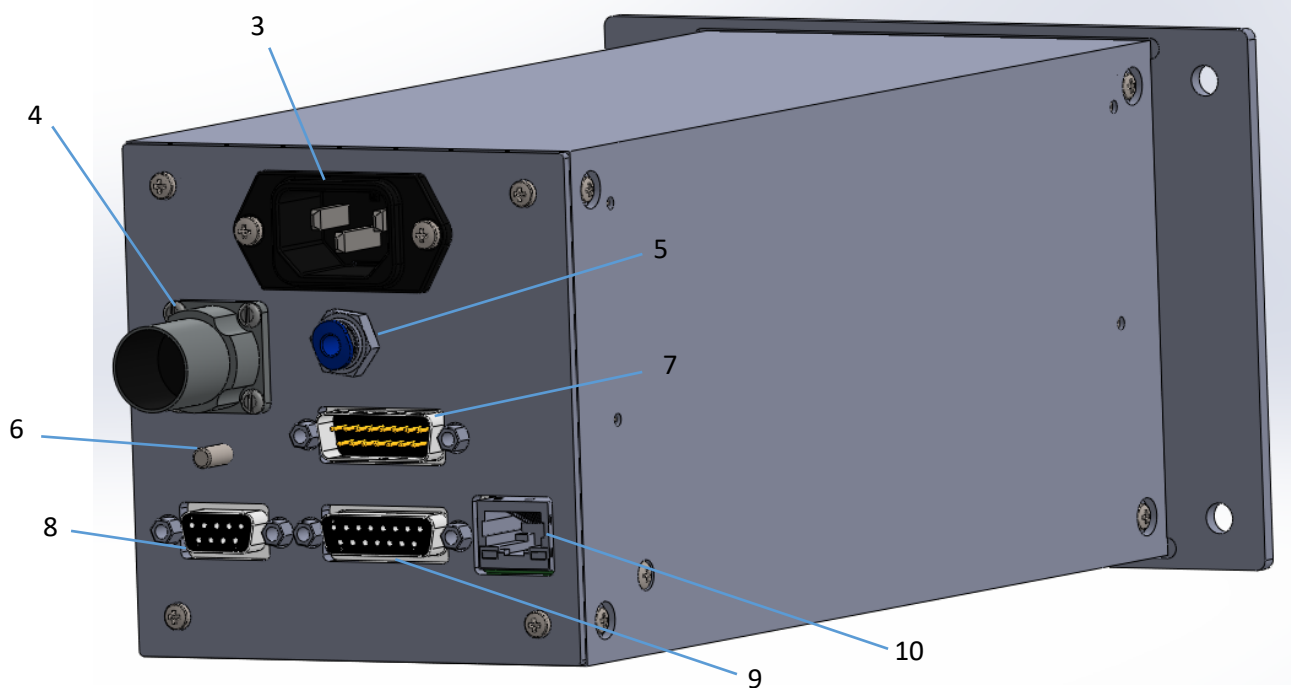

N°	Designation	N°	Designation
3	XLINE - Power Inlet IEC C14 Male	7	XIO 2 – D Sub 15 Male
4	XMOT – Motor connector	8	XSAFE – D Sub 9 Female
5	MAS - Pneumatic quick fit OD 4 mm - Motor air supply monitoring	9	XIO 1 – D Sub 15 Female
6	Earth connection M4	10	XETH – RJ 45 (Optional)

VI. General

A. Introduction

The JET drive series is available as a single axis drive and is optimised in term of function and cost-effectiveness keeping the highest Swiss quality standards.

The drive system allows easy operation and setup through modern and easy to use user software. The system enables simple and fast connection with various pluggable connectors for an easy setup and exchange if necessary.

A wide range of spindle & servo motor type can be connected to the drives and advanced control can be achieved with the encoder interface.

B. Technical data

Technical data	JET
Ambient temperature during operation	0°C to +40°C – When using the drive to its maximum, to keep the ambient temperature within limits it's advised to use forced ventilation on the electrical cabinet with a minimum of 10 CFM flow per axis.
Ambient temperature for transportation	-25°C to +70°C
Ambient temperature for storage	-25°C to +55°C
Air Humidity	5% to 85% non-condensing
Corrosion protection	Under extreme operating conditions (known corrosive environment), special measures must be agreed with the manufacturer and implemented by the user.
Operating Altitude	Up to 1000m above sea level without restrictions, from 1000m to 2500m max with power reduction (2%/100m)

Permissible installation position	Fixed by front plate
Ventilation	Natural convection
Protection class	IP 50
Special operation conditions	The usability of the drives under harsh operating conditions or other unfavourable conditions must be ascertained individually in consultation between the manufacturer and the user.

C. Electrical data

Technical Data for	JET_010	JET_020
Power supply voltage	1 x 110 to 230 VAC (45 to 65 Hz) - Internal DC bus customizable	
Output voltage ⁽¹⁾	16VAC to 56 VAC	
Output RMS current ⁽²⁾⁽¹⁾	7A	14A
Output Max RMS current ⁽²⁾	10A	20A
Output power ⁽¹⁾⁽²⁾	193W to 678W	387W to 1900W
Output power Max ⁽¹⁾⁽²⁾	277W to 969W	554W to 2770W
Internal brake resistor	22 Ohms / 40W	
Braking power	40W / 200W for 5s / 400W peak	
Braking Threshold ⁽⁵⁾	Adapt automatically based on power voltage, Absolute max hardware limit 92VDC	
Ambient temperature range	0°C to +40°C non condensing	
PWM Switching Frequency	Space Vector Modulation PWM at 20kHz or 80kHz, selectable	
Max output frequency	2000 Hz	
Max motor speed (1 pole pair)	120000 RPM	
Auxiliary powers	24VDC Output, 5V DC Output, 12VDC Output, 24VDC Input ⁽⁴⁾	
Compatible motors	Asynchronous and Synchronous motor with sensor or sensorless	

⁽¹⁾ Dependant of power supply selection (refer to Internal DC bus), ⁽²⁾ Providing sufficient cooling; Max value for 5s, ⁽³⁾ S1 Op., incl. Power supply, without brake chopper

⁽⁴⁾ Not mandatory for operation, necessary to keep errors or position in case of power supply interruption

⁽⁵⁾ Threshold compare to the power supply voltage adjustable via software

Internal DC bus	JET_010	JET_020
JET_xxx_1515-13		DC Bus 30V - Continuous RMS 13A
JET_xxx_2424-7	DC Bus 48V - Continuous RMS 7A	
JET_xxx_2424-14		DC Bus 24V - Continuous RMS 14A
JET_xxx_3636-5	DC Bus 72V - Continuous RMS 5A	
JET_xxx_3636-10		DC Bus 36V - Continuous RMS 10A
JET_xxx_5555-6	DC Bus 55V - Continuous RMS 6A	
JET_xxx_xxxx-x	Other variant on request, contact ADX	

D. Control & Interfaces

Control & interfaces	JET_010	JET_020
Control interfaces	Analog +/- 10VDC, Ethernet, USB	
Control Methods	Speed loop, current loop, position loop	
Motor Feedback	A ± / B ± / Z ± TTL interface or 1VSS interface, Observer algorithm for Brushless & Asynchronous motors	
Inputs	5 x Digital inputs (Soft. configurable)	
Outputs	4 x Digital outputs, 1 x NO/NC Relay (Soft. configurable)	
Safety	Safe Torque Off (STO)	
Air supply monitor	1 x Pressure control for motor's air supply	
Temperature monitor	1 x Internal monitoring, 1 x external sensor connection	
Parameter settings	Via USB or Ethernet and Windows based application	

E. Mechanical data

Dimensions	JET_010	JET_020
Height x Width x Depth	105 x 145 x 224 mm	
Weight	3.5 Kg	
Mounting Options	Front plate	

F. Dimensions

All measurements are in millimetres. Simplified 3D step available on request.

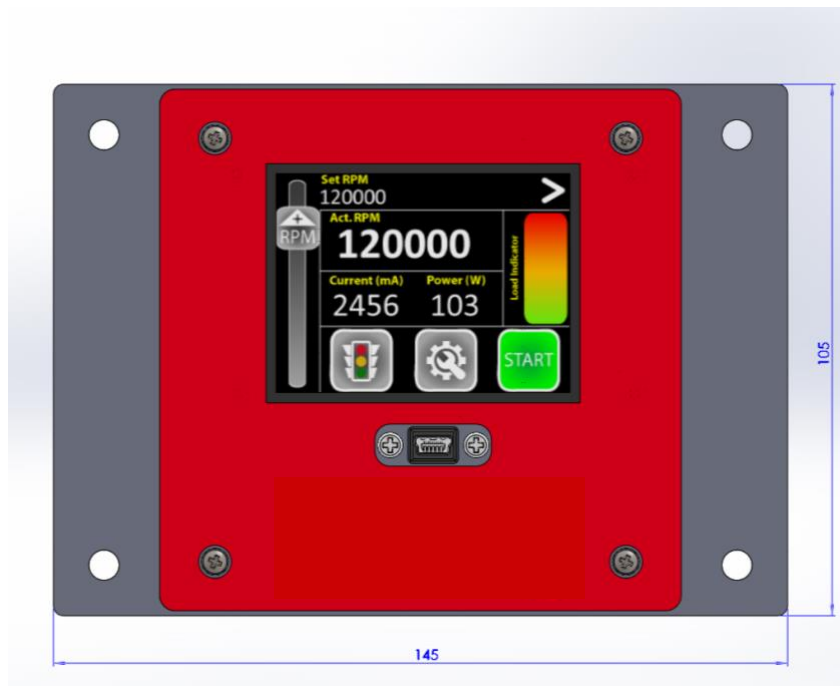

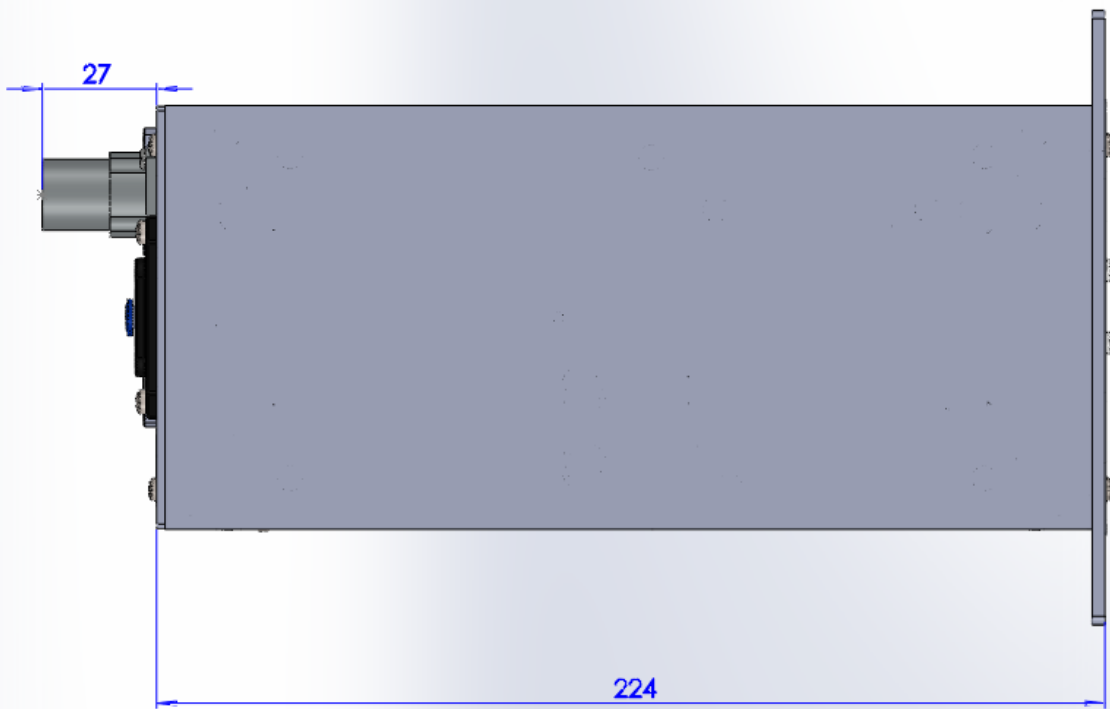
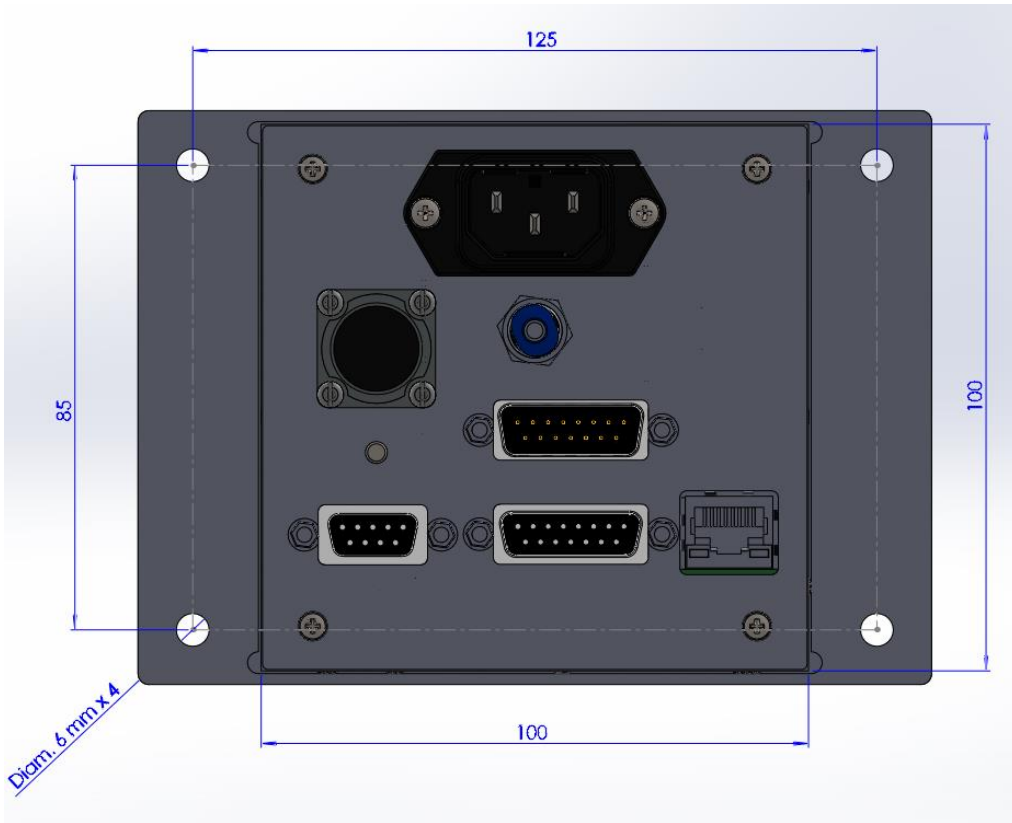

VII. Properties

- Very easy setup, integrated HMI, fast installation
- Low inductance High speed Spindle specialized drive
- Wide DC bus voltage range from 24 to 72 VDC
- Integrated power supply
- DC link management and integrated braking resistor
- Encoder feedback or sensorless
- High speed capture inputs
- High speed Space Vector Modulation (SVM) and current control
- Observer algorithm for asynchronous and synchronous sensorless control
- Easy to use user software with USB or Ethernet connection
- Safe torque off SIL-2
- Integrated temperature control
- Compact, all in one design for simple integration

VIII. Mechanical installation



Caution – Risk of injury!

- The drives may only be installed by trained, qualified personnel. The qualified personnel must know and comply with the national accident prevention regulations.
- Safety boots must be worn.



Caution – Risk of injury through electric shock!

- De-energise all electrical components (Drives, control cabinet, etc.) before starting the installation or deinstallation.



Destruction of the drive!

- Always install the drive vertically.
- Provide adequate ventilation for the drive. The permissible ambient conditions are specified in the “Technical data” section.
- It is essential to adhere to the required distances (see below diagrams).



WARNING

Caution – Risk of injury through electric shock!

- Take care that the mounting plate is earthed (grounded) properly.



Attention

Grounding!

- If the ground connection of the drive is not done as specified it is possible to get trouble with some EMC issues.

A. Mounting fixations

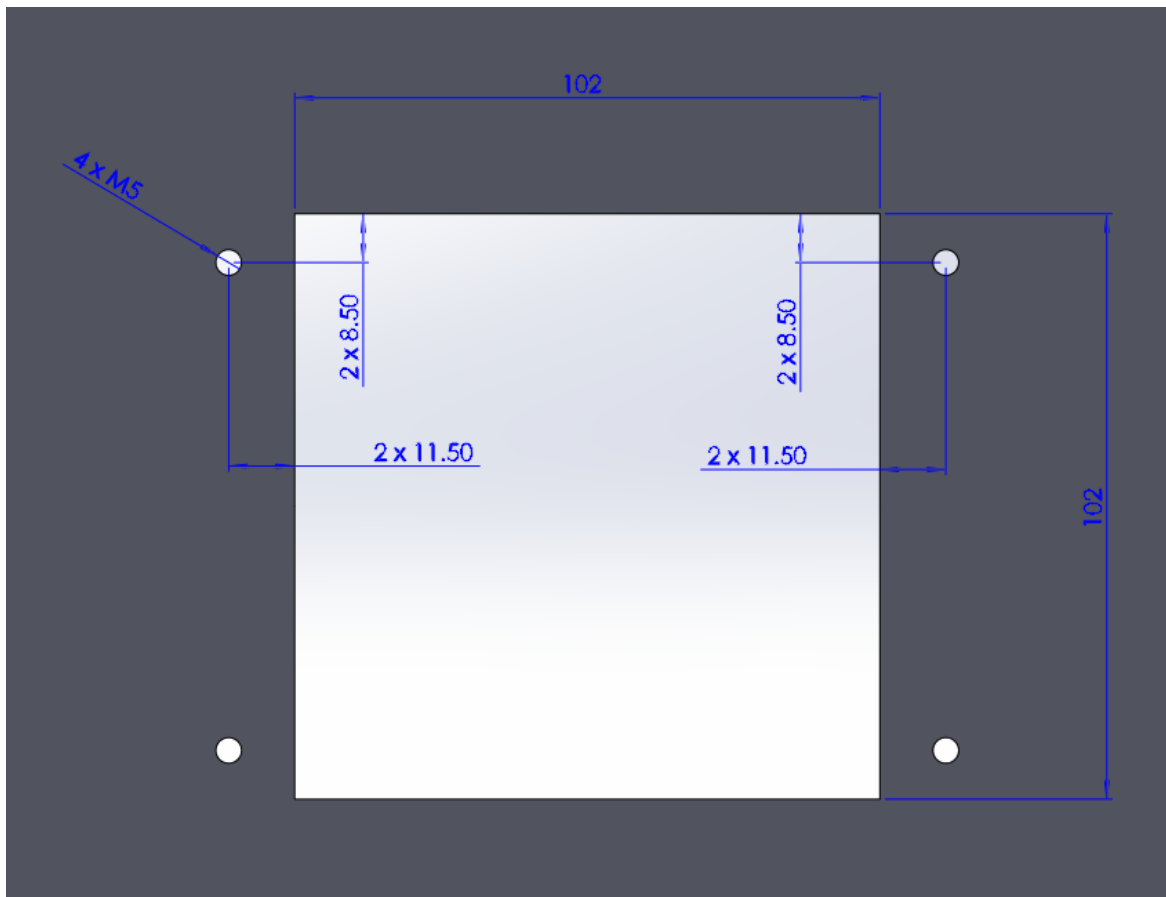

Indicative panel cut-out.

IX. Installation



WARNING

Caution – Risk of injury!

- The drives may only be installed by trained, qualified personnel. The qualified personnel must know and comply with the national accident prevention regulations.
- Safety boots must be worn.



WARNING

Caution – Risk of injury through electric shock!

- De-energise all electrical components (Drives, control cabinet, etc.) before starting the installation or deinstallation.



DANGER

Serious risk of injury though electric shock!

- Due to the DC link capacitors, dangerous voltage may persist at the DC link contact (if present) after the drive has been disconnected from the main supply. After disconnecting the drive wait at least 5 minutes, the device is safe once the DC link voltage has fallen below 50VDC.



WARNING

Caution – Risk of injury through electric shock!

- Before installation, wiring and commissioning it is essential to read the section on “safety”.
- Before installing, uninstalling or connecting the drive and motors please note the following:
 - Remove all relevant main fuses
 - Switch off the main system switch and secure it with a lock
 - Put up a warning sign
- The control and power connection for the motors may be live, even if the motor is prevented from rotating by any mechanical constrain.





Attention

Destruction of the drive!

- Check the rated voltage and current of the drive and the connected motor(s).

A. Input / Output connections

1. XMOT – TE Intercontec 917 receptable

Connector	Pin	I/O	Name	Meaning	With option motor auto Parameter detection	
					Name	Meaning
 BEGA908NN0000150A000 Female contacts: 4 x 60.159.11 – 1 mm 5 x 60.205.11 – 0.6 mm Matting connector (Option)  BSTA906NN0085201A000 Male contacts: 4 x 61.141.11 – 1 mm 5 x 61.178.11 – 0.6 mm	a	I	THMOT-	Motor temperature sensor -	Ref	Reference to activate bit
	b	I	THMOT+	Motor temperature sensor +	Bit 0	Binary coding 2 ⁰
	c	I	NC	Not Connected	Bit 1	Binary coding 2 ¹
	d	I	NC	Not Connected	Bit 2	Binary coding 2 ²
	e	I	NC	Not Connected	Bit 3	Binary coding 2 ³
	E	NA	PE	Protective conductor (Earth)		
	3	O	W	Motor phase W		
	2	O	V	Motor Phase V		
	1	O	U	Motor Phase U		

2. XLINE

Connector	Pin	I/O	Name	Meaning
 IEC C14	1	NA	L	Line
	2	NA	PE	Protective conductor (Earth)
	3	NA	N	Neutral

Fusing Single-Phase AC supply:

It's recommended to use a safety fuse on the AC line as per below table, depending on country dependant regulations, this might be mandatory.

	110 VAC	230 VAC
AC supply*	5AT	3AT

*Application class "gG" Mains fuses or "C" type automatic circuit-breakers must be used.

3. XIO 1 – D Sub 15P Female

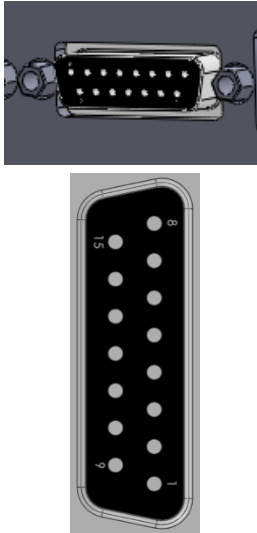
Connector	Pin	I/O	Name	Meaning	Default function
	1	O	12V OUT	12 VDC supply voltage, limited to 100 mA ⁽²⁾	
	2	I	A_IN -	Analog input -	
	3	I	ENA_2	Enable 2 digital input ⁽¹⁾	Start / Stop ⁽³⁾
	4	I	ENA_1	Enable 1 digital input	Enable drive ⁽³⁾
	5	I/O	GND	Ground	
	6	O	MO_2	Multi. digital output 2 ⁽¹⁾	Non-Zero speed
	7	I/O	MCC	Digital Outputs common	
	8	I	MI_1	Multi. digital Input 1 ⁽¹⁾	
	9	I/O	GND	Ground	
	10	I	A_IN +	Analog input +	
	11	I	MI_3	Multi. digital Input 3 ⁽¹⁾	External control selection ⁽³⁾
	12	I	MI_4	Multi. digital Input 4 ⁽¹⁾	Reset
	13	O	MO_3	Multi. digital output 3 ⁽¹⁾	Speed reached
	14	O	MO_1	Multi. digital output 1 ⁽¹⁾	Drive operational
	15	I	MI_2	Multi. digital Input 2 ⁽¹⁾	Internal set point selection ⁽³⁾

⁽¹⁾ Configurable via ADM software, ⁽²⁾ Referenced to GND, ⁽³⁾ Refer to chapter [XI](#) for motor start truth table with default I/O settings



Attention

Connectors are close:

XIO 1 & XSAFE are physically close, pay attention to the selection of the mating connector's covers as some model are too large and do not fit in. The two fixation threads are separated by 7 mm as illustrated below.

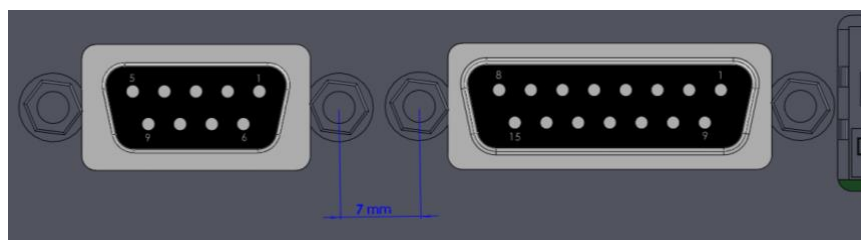

4. XIO 2 - D Sub 15P Male

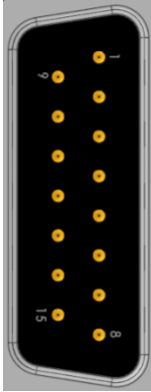
Connector	Pin	I/O	Name	Meaning
 	1	I/O	GND	Ground
	2	O	20V_OUT	18-22 VDC supply voltage, limited to 50 mA ⁽²⁾
	3	I	A_IN	Encoder channel A input +
	4	I	A/_IN	Encoder channel A input -
	5	I	B_IN	Encoder channel B input +
	6	I	Hall1_IN	Hall sensor input 1
	7	I	Hall2_IN	Hall sensor input 2
	8	O	V5_FB	5 VDC supply voltage, limited to 250 mA ⁽²⁾
	9	I	24V_IN	15 to 28 VDC logic supply input ⁽¹⁾⁽²⁾
	10	O	MO_4	Multi. digital output 4 ⁽³⁾
	11	I	Hall3_IN	Hall sensor input 3
	12	I/O	GND	Ground
	13	I	B/_IN	Encoder channel B input -
	14	I	Z_IN	Encoder channel Z input +
	15	I	Z/_IN	Encoder channel Z input -

⁽¹⁾ Not mandatory, logic supply needed to keep the control unit live when unpowered on XLINE; ⁽²⁾ Referenced to GND, ⁽³⁾ Configurable via ADM software.

5. XSAFE - D Sub 9P Female

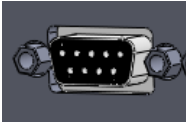
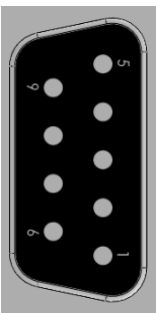
Connector	Pin	I/O	Name	Meaning
 	1	I	STO_A	Safe torque off channel 1 + ⁽³⁾
	2	I	STO_B	Safe torque off channel 2 + ⁽³⁾
	3	I/O	GND	Ground
	4	O	REL_A	Relay contact A _ Normally open ⁽¹⁾
	5	O	REL_B	Relay contact B _ Normally close ⁽¹⁾
	6	O	20V_OUT	18-22 VDC supply voltage, limited to 50 mA ⁽²⁾
	7	I	STO_A/	Safe torque off channel 1 - ⁽³⁾
	8	I	STO_B/	Safe torque off channel 2 - ⁽³⁾
	9	O	REL_C	Relay common

⁽¹⁾ Configurable via ADM software, ⁽²⁾ Referenced to GND, ⁽³⁾ Mandatory, see safe torque off function explanations.



Attention

Connectors are close:

XIO 1 & XSAFE are physically close, pay attention to the selection of the mating connector's covers as some model are too large and do not fit in. The two fixation threads are separated by 7 mm as illustrated below.

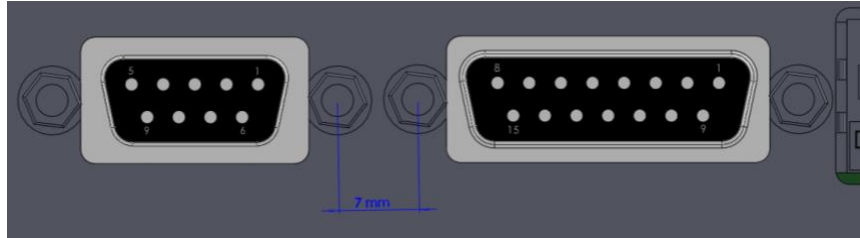









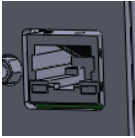
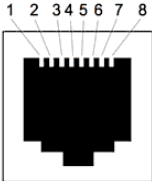
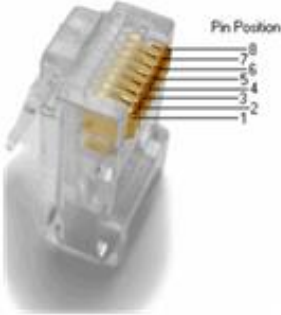















6. Earth connection



For a better grounding and noise immunity, it is advised to connect the JET motor drive to the machine Earth using the circled M4 connection and a crimp eyelet terminal.

7. XETH – RJ45 Jack Ethernet Connection (Optional)

Connector																																					
  Rj-45 Jack (Female)																																					
	<table border="1"> <thead> <tr> <th>Pin</th> <th>Name</th> <th>Description</th> <th>Cable Color</th> </tr> </thead> <tbody> <tr> <td>1</td> <td>TX_D1+</td> <td>Tranceive Data+</td> <td> white/green</td> </tr> <tr> <td>2</td> <td>TX_D1-</td> <td>Tranceive Data-</td> <td> green</td> </tr> <tr> <td>3</td> <td>RX_D2+</td> <td>Receive Data+</td> <td> white/orange</td> </tr> <tr> <td>4</td> <td>BI_D3+</td> <td>Bi-directional Data+</td> <td> blue</td> </tr> <tr> <td>5</td> <td>BI_D3-</td> <td>Bi-directional Data-</td> <td> white/blue</td> </tr> <tr> <td>6</td> <td>RX_D2-</td> <td>Receive Data-</td> <td> orange</td> </tr> <tr> <td>7</td> <td>BI_D4+</td> <td>Bi-directional Data+</td> <td> white/brown</td> </tr> <tr> <td>8</td> <td>BI_D4-</td> <td>Bi-directional Data-</td> <td> brown</td> </tr> </tbody> </table>	Pin	Name	Description	Cable Color	1	TX_D1+	Tranceive Data+	 white/green	2	TX_D1-	Tranceive Data-	 green	3	RX_D2+	Receive Data+	 white/orange	4	BI_D3+	Bi-directional Data+	 blue	5	BI_D3-	Bi-directional Data-	 white/blue	6	RX_D2-	Receive Data-	 orange	7	BI_D4+	Bi-directional Data+	 white/brown	8	BI_D4-	Bi-directional Data-	 brown
Pin	Name	Description	Cable Color																																		
1	TX_D1+	Tranceive Data+	 white/green																																		
2	TX_D1-	Tranceive Data-	 green																																		
3	RX_D2+	Receive Data+	 white/orange																																		
4	BI_D3+	Bi-directional Data+	 blue																																		
5	BI_D3-	Bi-directional Data-	 white/blue																																		
6	RX_D2-	Receive Data-	 orange																																		
7	BI_D4+	Bi-directional Data+	 white/brown																																		
8	BI_D4-	Bi-directional Data-	 brown																																		

8. MAS - Motor air supply monitoring - Pneumatic quick fit OD 4 mm



If enable ⁽¹⁾, the motor air supply monitoring system (MAS) is constantly checking that the motor is supply with air by ensuring that a sufficient pressure is present. The MAS must be connected in parallel with the motor air supply with a tube O.D 4 mm. The Absolut maximum applicable pressure is 10 Bar.

⁽¹⁾ Configurable via ADM software.



Attention

Destruction of the function!

The MAS system must supply with clean dry air, if the air supply to the motor contains moisture or oil, a diaphragm seal must be used to isolate the MAS pressure sensor from the contaminant.

B. Connection examples

1. Digital outputs on XIO 1 & XIO 2

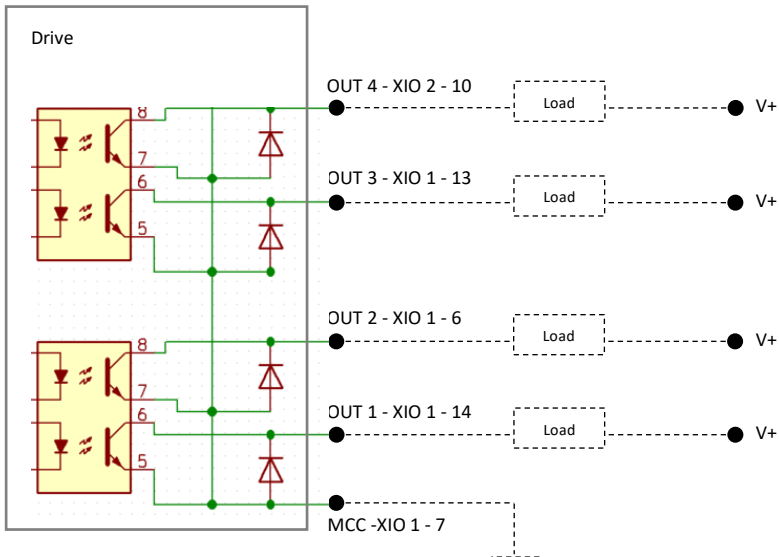

Isolated low side driver

- Max 50 mA per channel
- Max 75 VDC
- Protected against wrong polarity
- Digital output meaning can be defined through the ADM software.

2. Digital input on XIO 1

Digital inputs functions can be defined through the ADM software.

All inputs are active low, they must be shortened to GND.

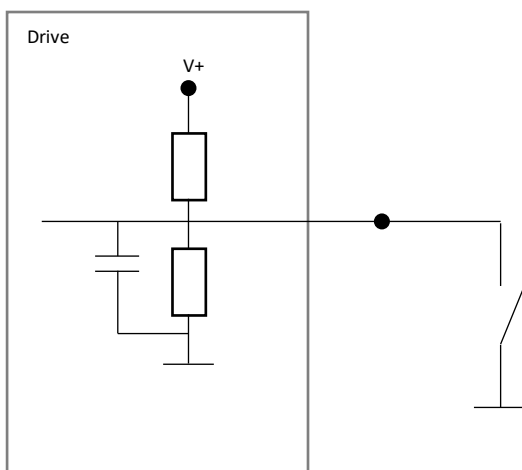

3. Analog input on XIO 1

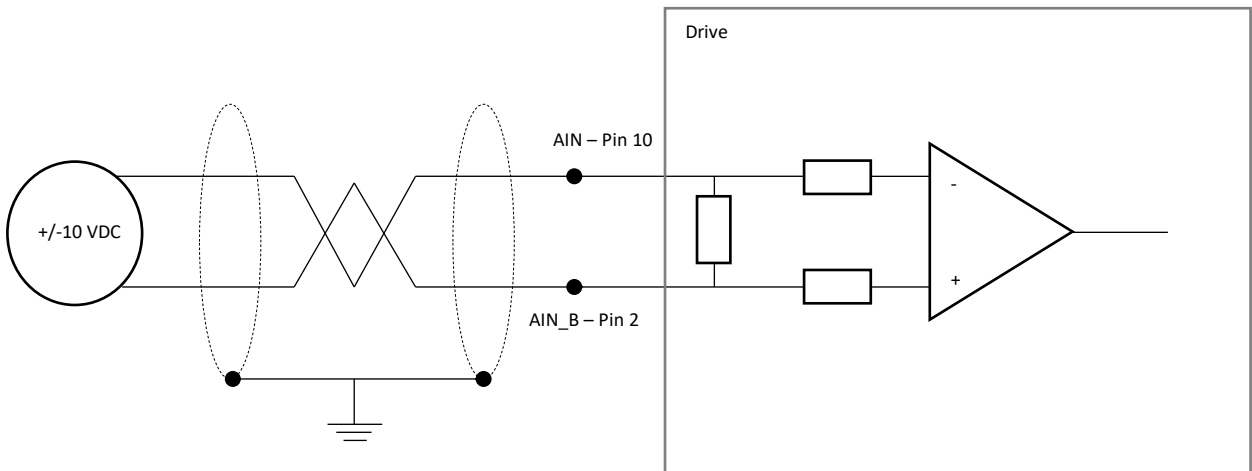

Voltage interface for input voltage range +/-10V.

Prefer shielded twisted pair wiring for noise immunity.

Fully differential input, polarity can be physically reverted to inverse the command.

4. Motor temperature sensor on XMOT

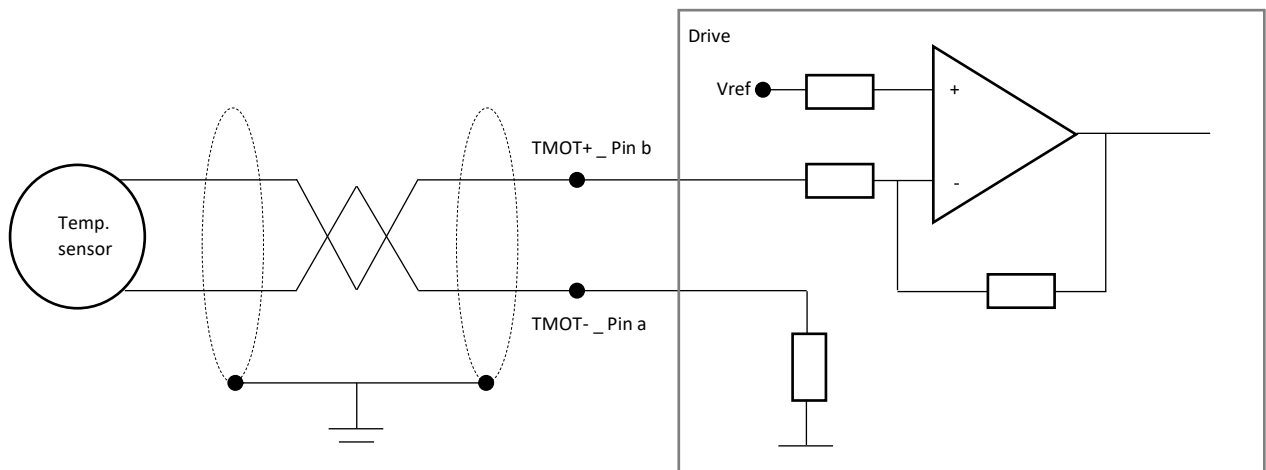

This input is used to monitor the motor temperature, it supports various resistive (NTC/PTC) temperature sensor such as KTY and PT. It can also be left un-connected or be used with thermo switch.

Sensor parameters are set through the ADM software.

Prefer shielded twisted pair wiring for noise immunity.

5. Option – Motor auto parameter detection on XMOT

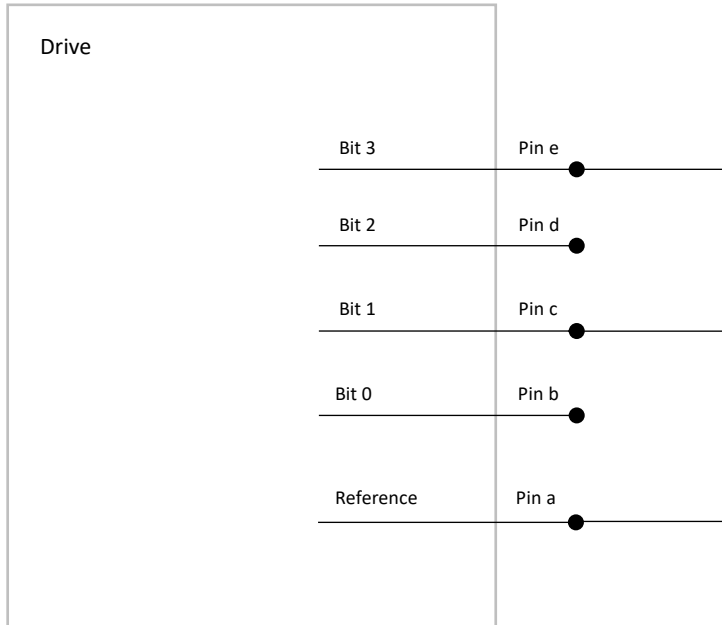

<- Example:

Bit 1 and bit 3 are activated, the parameter number selected is then:

$$(2^0 \times 0) + (2^1 \times 1) + (2^2 \times 0) + (2^3 \times 1)$$

$$= (2^1 \times 1) + (2^3 \times 1) = 2 + 8 = 10$$

With this option an external coding of the parameter number (Refer to X.E.4) to be used with the motor can be made, the selected parameter number is encoded on 3 bits, the zero value is excluded and thus selection from parameter number 1 to 15 is possible.

At power on or after a drive reset, the parameter number will be read out of XMOT and applied. Moreover, at each motor start, the drive will control the active parameter number against the XMOT read out, if a mismatched is detected and error will occur.

This function is optional and shall be ordered with the drive, if the function is available, it can be activated or de-activated from the control HMI, Refer to X.E.4.

6. Relay on XSAFE

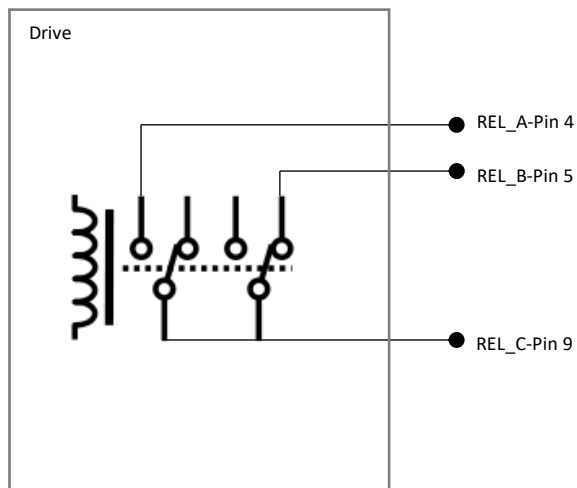

Relay output function can be defined through the ADM software, default setting is error state.

Contact rating:

- 2A 30 VDC
- 0.5A 125 VAC

7. Encoder input on XIO 2

The encoder interface is compatible with incremental encoders with differential input in TTL or Sin/cos 1 Vpp.

TTL differential encoder input:

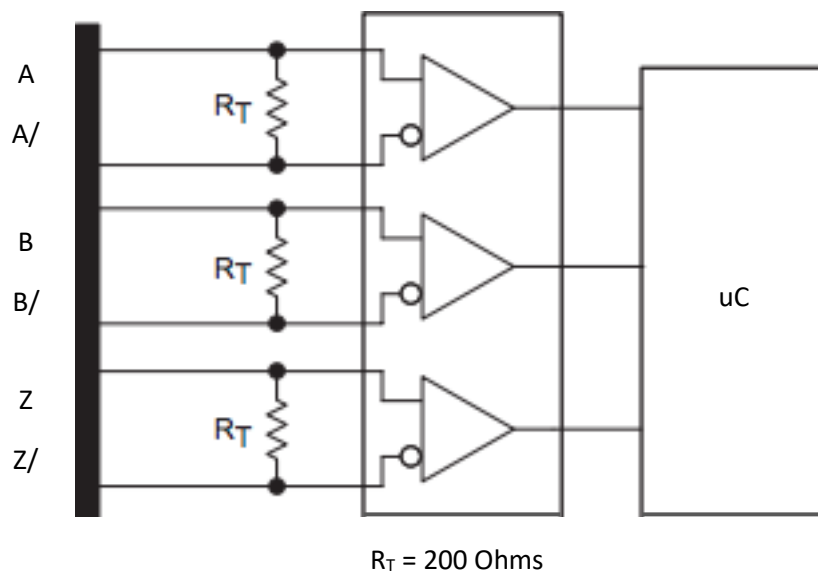

1Vpp differential encoder input (per channel):

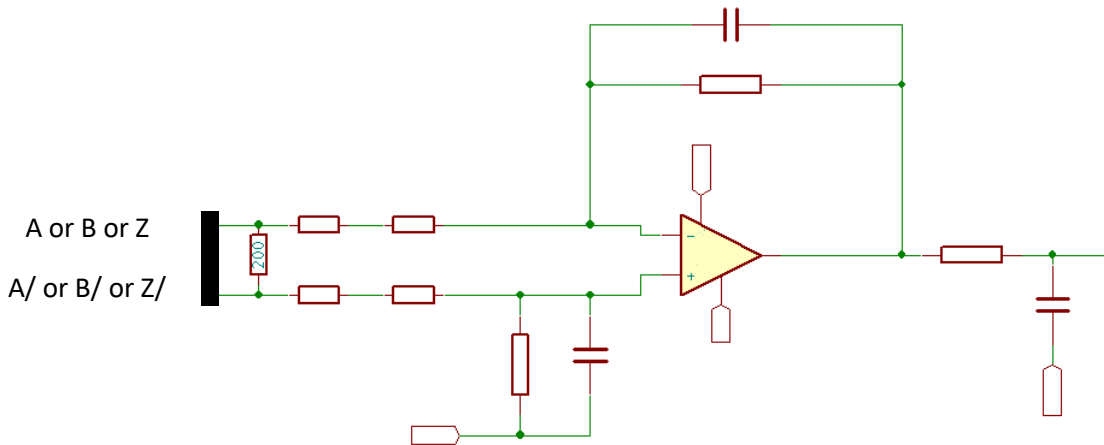

8. Hall sensor inputs on XIO 2

Hall sensor inputs are compatible with 5V TTL inputs.

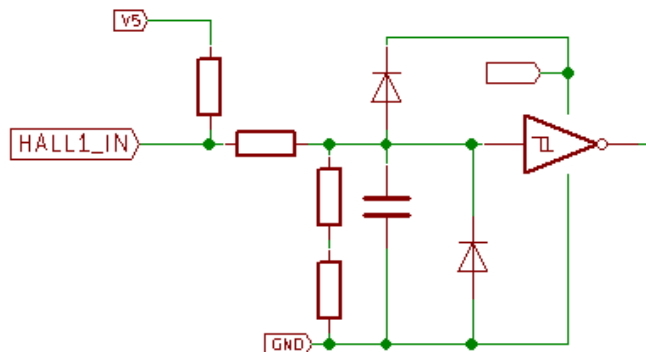

9. MAS – Motor Air Supply Monitoring

The MAS system shall be connected in parallel of the air motor supply with a Y splitter connector (avoid T) located as close as possible from the pressure regulator. Both lines should have the same diameter. If the tube diameter arriving to the drive is different than 4 mm, an adaptor shall be placed as close as possible from the drive.

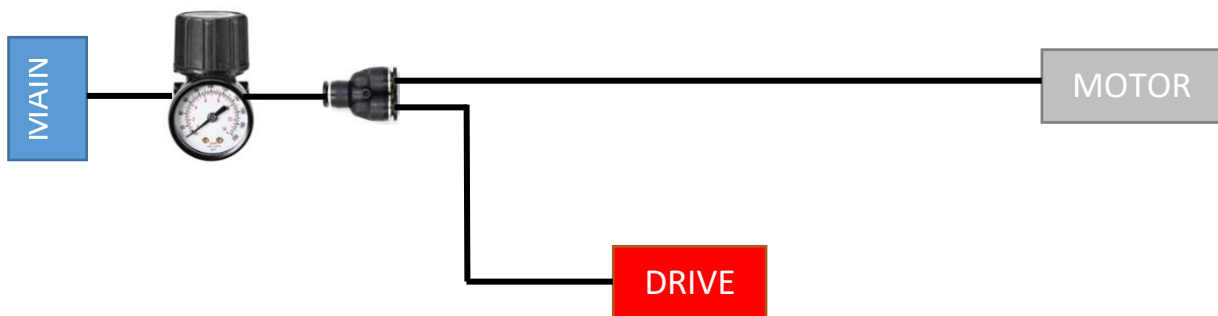

10. Safe torque off SIL 2 PL d on XSAFE

The STO (safe torque off) is a safety function that prevents motor driving torque in an emergency event.

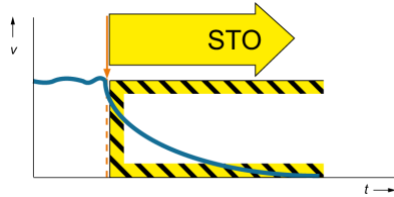

In order to reach the highest level of safety (SIL-2), the STO hardware implementation is composed of two redundant lines (STO_A/STO_B), the deactivation of a single of these lines will conduct to an immediate loss of motor driving torque.

The STO can also be use in standstill to avoid motor operation.

If the STO is not satisfied, a fault is present on the drive through the firmware and can be notified to an external device via an external output of the drive (not safety relevant as triggered by software), however the STO function is totally independent of the firmware operation as it is a pure hardware function.

When the STO is not connected it is impossible to apply power to the motor.



WARNING

Caution – Risk of injury through electric shock!

- The STO function does not provide protection against electric shock, only against hazardous movements.



Attention

Note

- The STO function is insufficient as a sole safety function for drives subject to permanent torque or force (e.g. Suspended loads).
- Bypassing of safety equipment is impermissible.
- Repair of the controller is impermissible.
- If the control ports STO_A or STO_B are deactivated with an active output stage, it will result in uncontrolled coasting of the motor. If uncontrolled coasting can result in a hazard or damage, additional measures are required. Stop function Category 0 – EN 60204-1:2007-6 / ISO 13849.
- SIL 2 – IEC 61508
- PL d – ISO 13849
- In the unlikely event of a failure of the motor controller output phase during STO status (simultaneous short circuit of 2 power semiconductors in different phases) may result in a limited movement of the rotor. The rotation angle / path corresponds to a pole pitch.
Examples: – Rotary axis, synchronous machine, 4-pole pairs < 45° at the motor shaft. – Linear motor, pole pitch 20 mm movement < 20 mm at the moving part.

The **output stage of the drive is only active** when the STO_A and STO_B positions are powered.

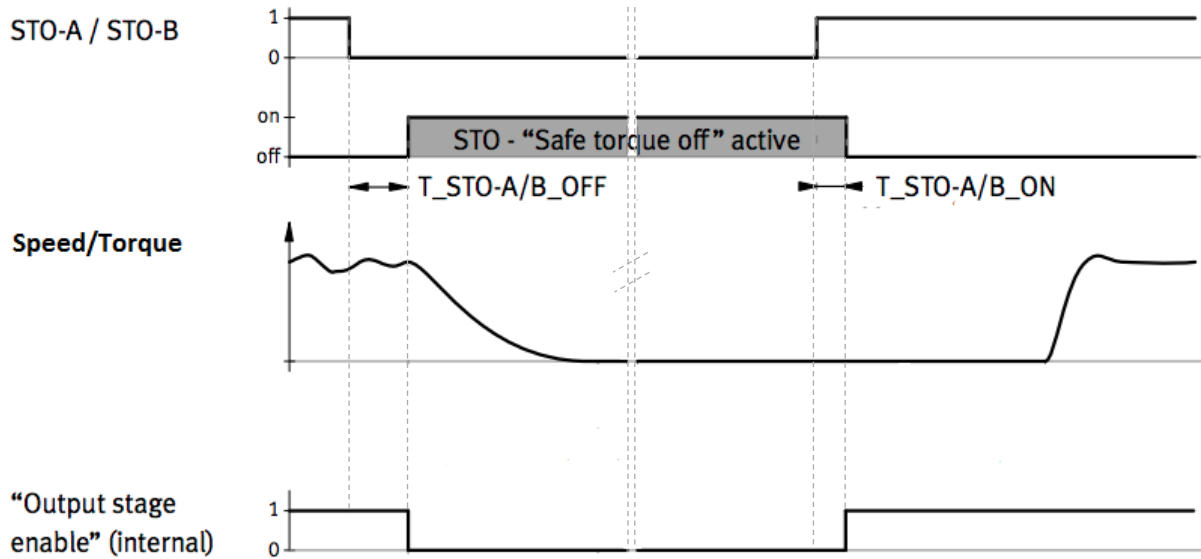

T_{STO-A/B_OFF} and T_{STO-A/B_ON} , Nominal 5 ms, Max 10 ms.

The safety function STO (safe torque off) is requested via the two control ports STO-A and STO-B.

These control ports permit the direct connection of safe semiconductor outputs:

- Electronic safety switching devices
- Active safety sensors, e.g. light curtains with OSSD signals
- Switch contacts (safety switching devices with relay outputs, passive safety sensors, e. g. forced position switches).

To request the safety function STO (safe torque off), the 24 V control voltage at both control ports STO-A and STO-B is switched off (0 V). If the two control ports are switched off simultaneously the STO function is active. If both channels are not actuated simultaneously, the STO function is nevertheless active at the first request. If a channel is not switched off, it is interpreted as an error and results in an error message being issued.

a) Description of safety function

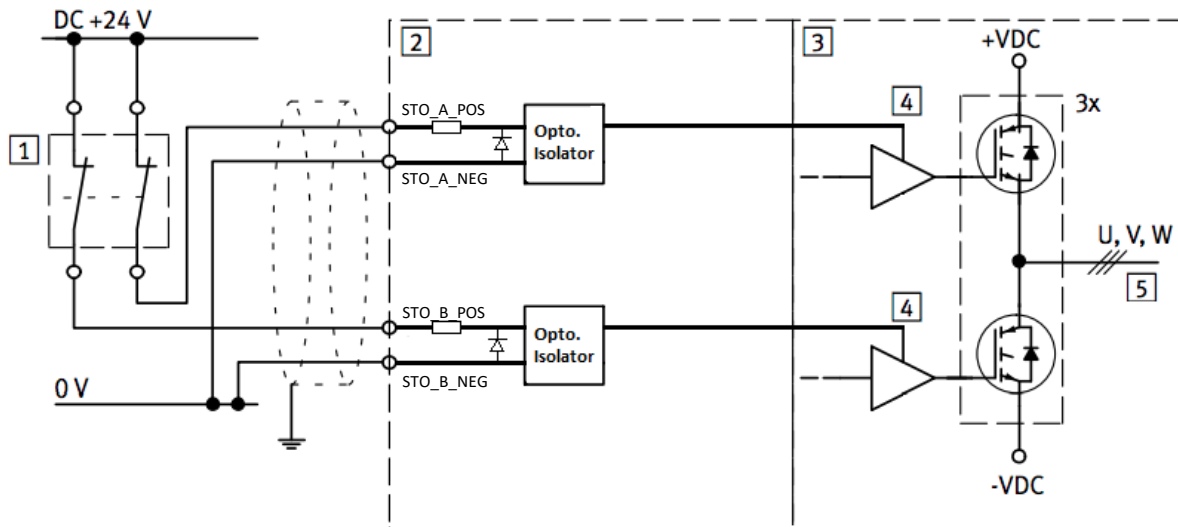

[1] Safety command device (e.g. Switch relay, safety switching device)

[2] Integrated safety STO function

[3] Power stage of the drive

[4] Driver logic

[5] Motor connection

b) OSSD compatibility

OSSD (Output Signal Switching Device) are test pulses for safety control, they allow the safety device emitting them to check periodically for any circuit issue such as short.

Those pulses are tolerated and therefore do not cause an activation of the STO function. The maximum test pulse width tolerated is 2 ms of off state.

c) *Wiring examples*

1. Direct wiring to an emergency stop switch

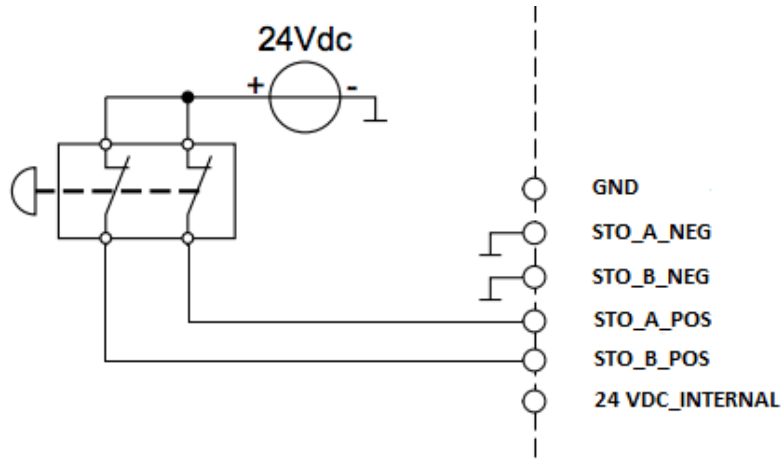

Any kind of safety switches can be connected in the same manner (e. g. safety door switches).

2. Direct wiring to an emergency stop switch with wiring monitoring

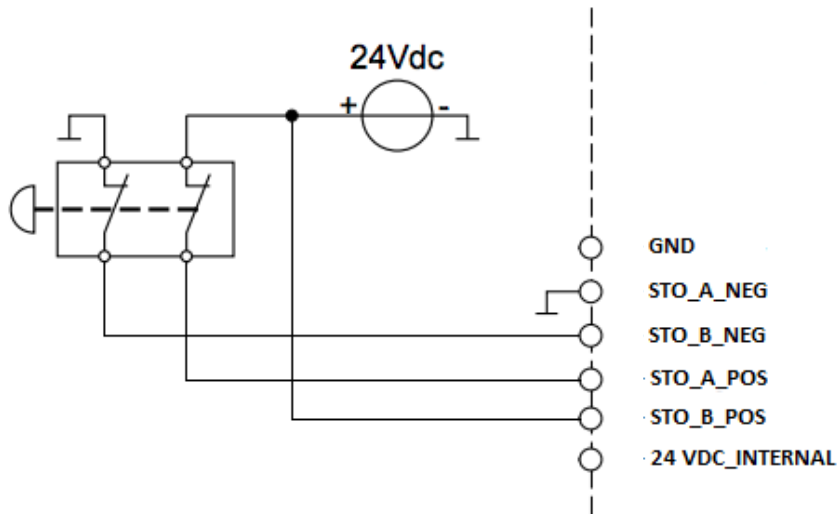

Any kind of safety switches can be connected in the same manner (e. g. safety door switches).

3. Connection to a safety module with OSSD test pulses

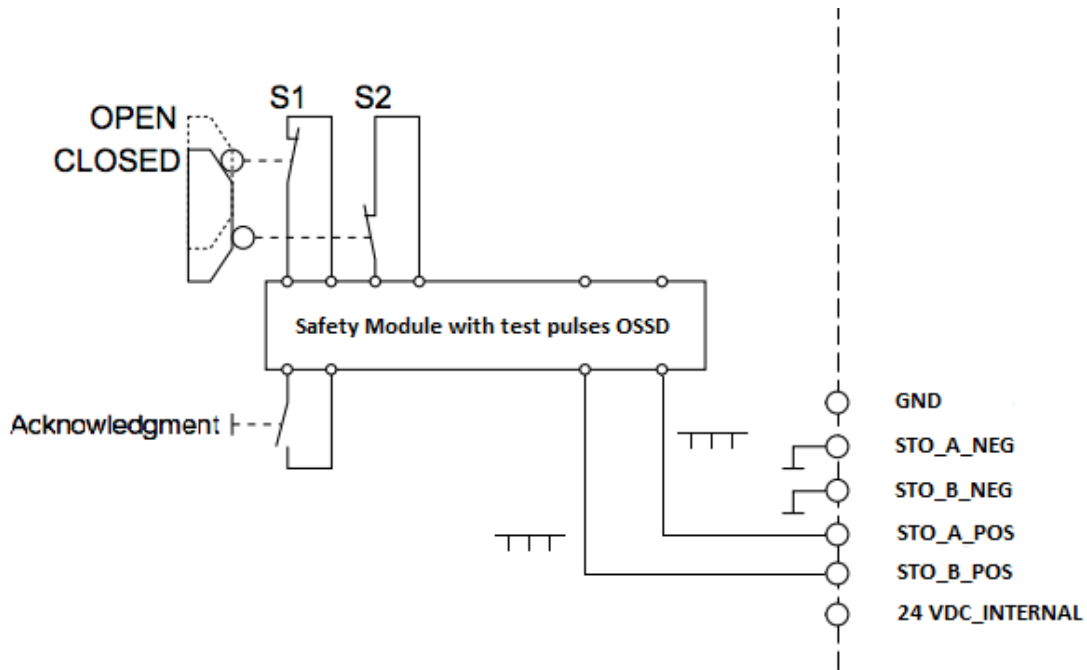

Any kind of safety switches can be connected to the safety module (e. g. safety door switches).

4. Bypassing the STO function



Attention

NOT SAFETY RELEVANT!

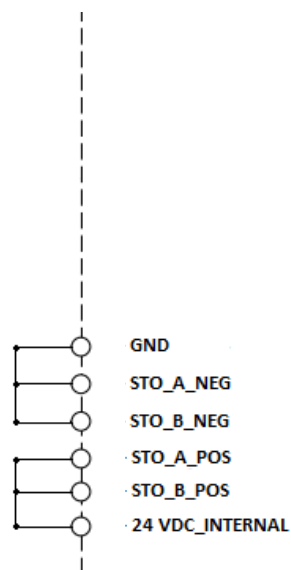

X. HMI Control

A. Main Page

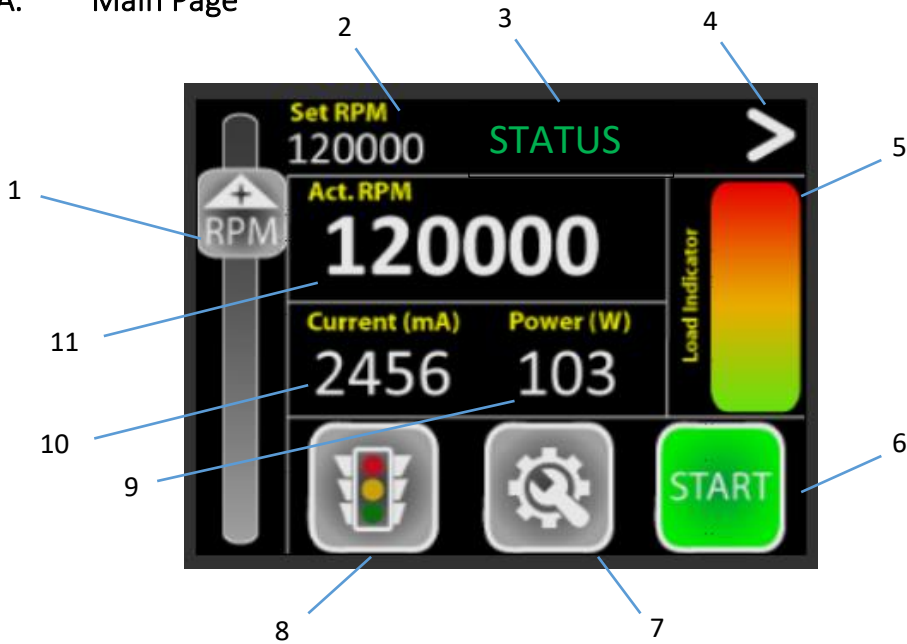

1- RPM Slider

Simply slide the slider up and down to adjust the target speed, which will display as Set RPM (2).

The slider is only active when the physical input “Internal set point selection” is active, see [IX.A.3.](#) or if the “force internal command” button have been pressed, see [Setup](#) page.



If none of the above conditions are met, the slider is deactivated and will appear as , in this case, only the external control via analog input is controlling the speed.

2- Set RPM

This is the current set point for the speed, it’s controlled via the slider. A speed set point can also be entered manually with the touch keyboard that will appear by pressing on Set RPM.

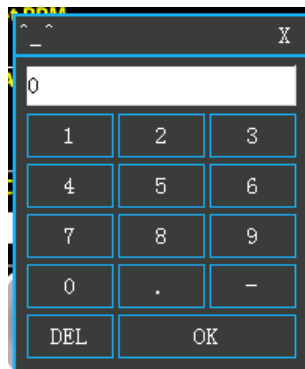

First, delete all characters with DEL, input the new value and press OK.

3- Status

The status text is present on all screens, it is colour coded, when the text is green, the drive is fully operational, when text is orange, there is a warning condition (the drive is still operational), when the text is red, an error condition exist.

The Status page can be accessed by pressing the button (8).

4- Next page

Go to next page, identical on all screens.

5- Load indicator

The load indicator provides the user with a quick view on the actual load, the load is proportional to the current supported by the motor, the continuous current supported by the motor is at 75% of the load indicator bar.

6- Start/Stop button

Simply click on this button to Start or Stop the motor.

The button is not active when the physical input “External control selection” is active, see [IX.A.3](#). It can be activated by the “force internal command” button located in the [Setup](#) page.



If the button is deactivated, it will appear as , in this case, only the external control via I/O is controlling the start/stop condition, see ENA_1 and ENA_2 function chapter [IX.A.3](#).

7- Setup page

Click on this button to go directly to the [setup](#) page.

8- Status page

Click on this button to go directly to the [status](#) page.

9- Power value

For synchronous motors, the power value is the real, instantaneous mechanical power of the motor, it's computed as:

$$P = C \times \omega$$

Where C is the instant torque, calculated from the Kt of the motor (torque constant in Nm/A) and the instant current of the motor in A.

Where ω is the motor rotation speed in rad/s.

For asynchronous motors, the power is calculated from the electrical power consumption on the internal DC bus of the drive at any given time. In this case $P = U(\text{bus}) \times I(\text{bus})$.

10- Current value

Instant current drawn by the motor in mA.

11- Act. RPM

Instant speed of the motor in RPM.

B. Load Only page

The load only page, display the load indicator in a full-page format to make it easily visible from further away. Refer to the [Main page](#) element 3, 4, 5 and 11 description.

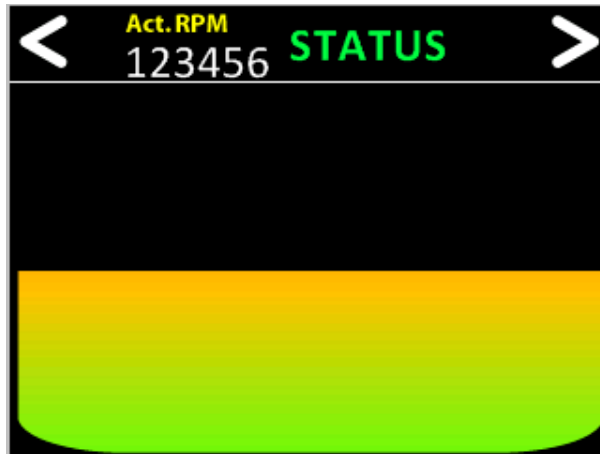

C. Scope page

The Scope page provides the user with a graphical view of important parameters for the last 20 seconds.

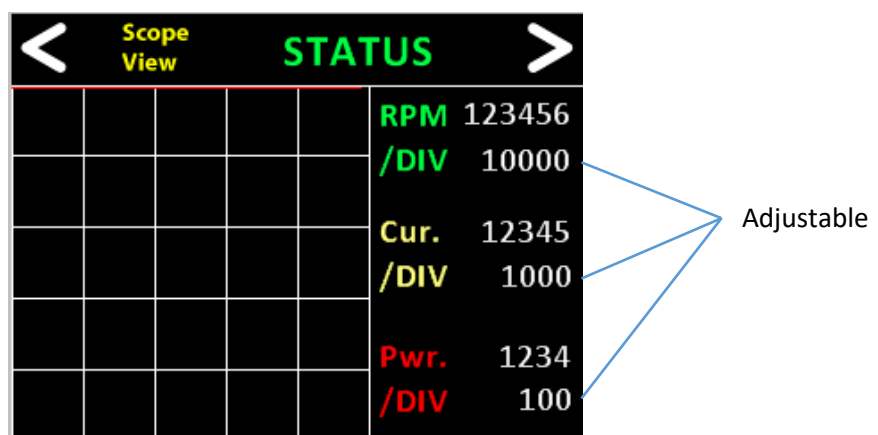

The displayed parameters are:

- Actual Speed RPM, green curve
- Actual Current in mA, yellow curve
- Actual Power in W, red curve

The /DIV represent the vertical scale of the scope for each parameter, it can be manually modified by clicking on the value and inputting a new scale factor with the touch keyboard.



First, delete all characters with DEL, input the new value and press OK.

D. Status page

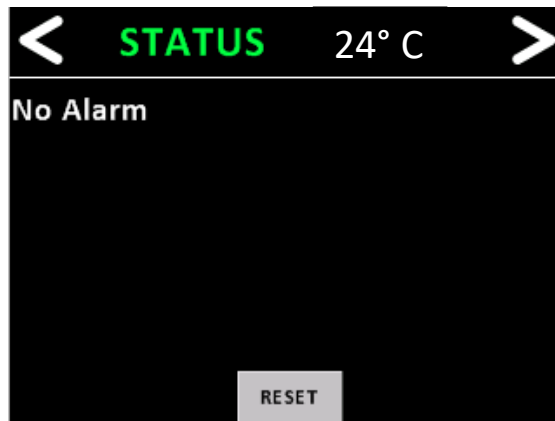

The status page provides a listing in plain text of the active(s) Error and Warning, as well as a drive temperature reading and a reset button.

A warning displays in orange coloured text, an error display in red coloured text.

The reset button can be used to try to clear the error/warning condition, if it doesn't clear, the source of the error warning is still present.

The drive temperature is the internal temperature of the drive. The drive will issue a warning at 60°C and will start derating from this limit.

E. Setup Page

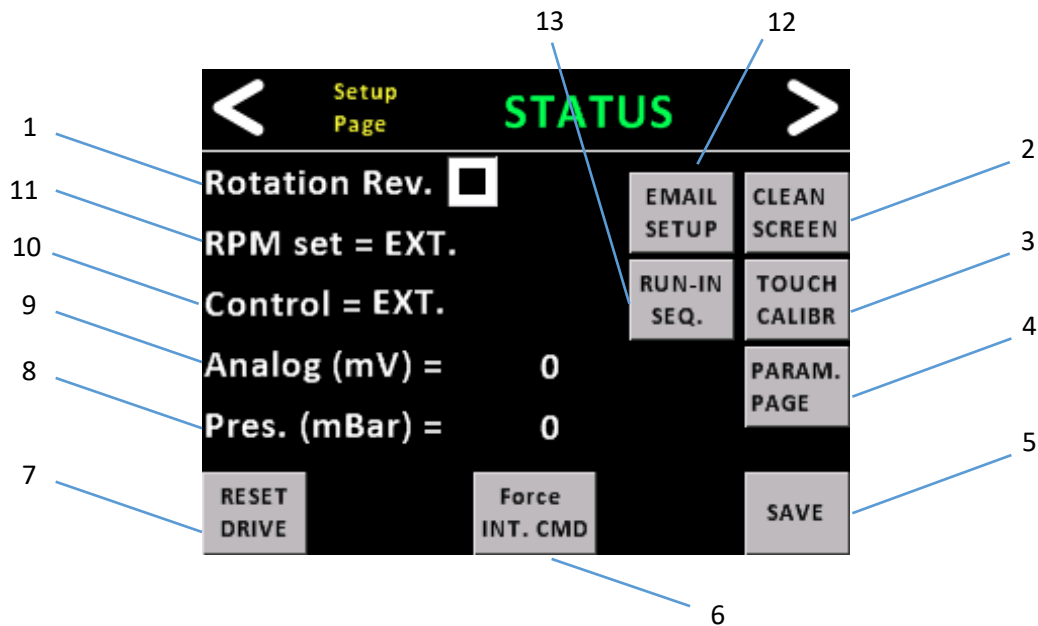

1- Reverse rotation

Check the check box to reverse the default rotation of the motor in internal command, press the save button to make the change permanent.

Note: In case of speed control with the analogue input (see [IV.B.3](#)), this setting has no effect, only a physical polarity inversion will change the rotation direction.

2- Clean screen

Pressing this button will open a screen with a 15 second timer without any touch screen functionality. While the timer is running, the user can freely clean the surface of the touch screen.

To clean your screen, use a screen cleaning wipe or a soft, dry, lint-free cloth. When necessary, you can dampen the cloth with one of the following: water, isopropyl alcohol (IPA) solution 70% or less, or eyeglass cleaner.

3- Touch screen calibration

It's normally not necessary to calibrate the screen, if the user experience miss-touch or inconsistent response of the touchscreen a recalibration sequence can be started by pressing this button, use a fine touch screen pen and follow the displayed procedure.

4- Parameter page

The drive embedded up to 25 pre-set parameters that can be selected with the below screen.

The parameter set "0" is the currently active one.

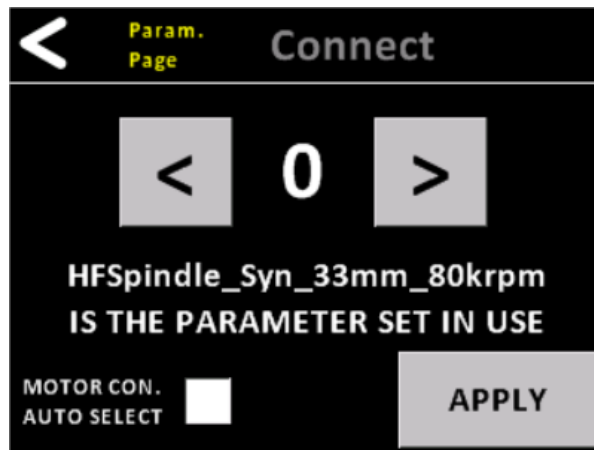

If the parameter set need to be changed, scroll with the arrows through the list until finding the applicable parameter set, then click apply.

The process will take several seconds, and the drive will reset. The parameter set “0” should now be the one selected.

If the option - Motor parameter auto selection is installed, the parameter set can be selected automatically through the motor connector coding (Refer to [IV.A.1](#) & [IV.B.5](#)). When the check box “Motor Con. Auto select” is selected or un-selected, the button “Apply” will change to “Save change”; press the button to save change and reset the drive.

When the motor parameter auto selection is active (check box ticked) it’s not possible to select parameters manually however, at power on or after a drive reset, the parameter number will be read out of XMOT and automatically applied. Moreover, at each motor start, the drive will control the active parameter number against the XMOT read out, if a mismatched is detected and error will occur.

If a change of motor is made while the drive is powered on, a reset drive (Refer to point 7 below) is necessary to load the new parameter set.

5- Save button

The save button is saving changes so they are kept at reset of reboot.

6- Force internal command button

The function allows the user to bypass the physical logical entries (see [IV.A.3](#)) of the drive that select the speed and control to be internal or external and set them to internal. In this mode the speed control is done through the RPM slider and the start/stop through the start/stop button of the main screen.

In order to read again the physical logical entry a drive reset is required.

7- Reset Drive

The reset drive function is a full reboot of the drive firmware, like a new start-up.

8- Pressure reading

Refer to [IV.A.8](#), Motor Air supply Monitoring. The read pressure is displayed here in mBar.

9- Analogue input voltage reading

Refer to [IV.A.3](#), Display the current analogue input value.

10- Control status

Display the current control status, if external, the start/stop function occurs through physical I/O. If internal, through the start/stop button of the main screen.

11- RPM control status

Display the current RPM control status, if external, the speed control occurs through the physical analogue input. If internal, through the RPM slider of the main screen.

12- Email setup

If the drive is connected to the internet, it can send event triggered emails to inform a user of any sort of event or warning / errors.

In this screen the user can set the email address where to receive emails from the drive, to change the email address, click on the line and input the new address with the touch keyboard, then press the update button.

The drive can be assigned with a specific name (up to 32 characters) under IoT device name with the same principle.

13- Run-In Sequence

Usually, high speed motors require a run-in sequence to be executed depending on the rest time or other parameters. The embedded Run-In sequence allows the user to set the run-in parameters and execute it automatically.

When entering the Run-in sequence page, the start/stop controls are taken over from potential I/O input, only the drive enable and the STO remains. Exiting the page will reset the drive to nominal setup.

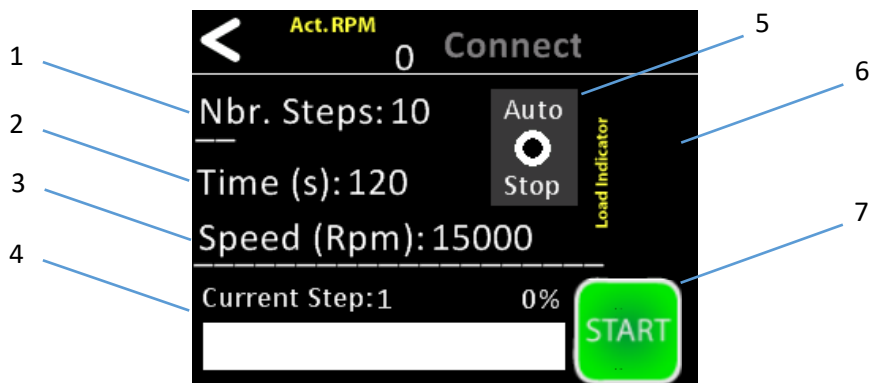

- 1- Set the number of required steps by touching the number and entering the desired number of steps with the touch keyboard.
- 2- Set the time per step by touching the number and entering desired time in seconds with the touch keyboard.
- 3- Set the speed increment per step by touching the number and entering desired increment in RPM with the touch keyboard.
- 4- Progress bar, completion % and current step indication.
- 5- Auto Stop button, when activated (As shown) the sequence will automatically stop the motor upon completion, if unselected, the motor will keep running at the last step's speed until the user press the stop button. A message of completion will be displayed.
- 6- Load indicator, refer to X.A.5.
- 7- Start/Stop of the motor and sequence.

Note:

The user cannot exit the page while the sequence is running.

The sequence execution is protected regarding the minimum and maximum speed set in the parameter set. The sequence will correct any input below the minimum speed to the minimum speed and correct any input above the maximum to speed to the maximum speed.

Example:

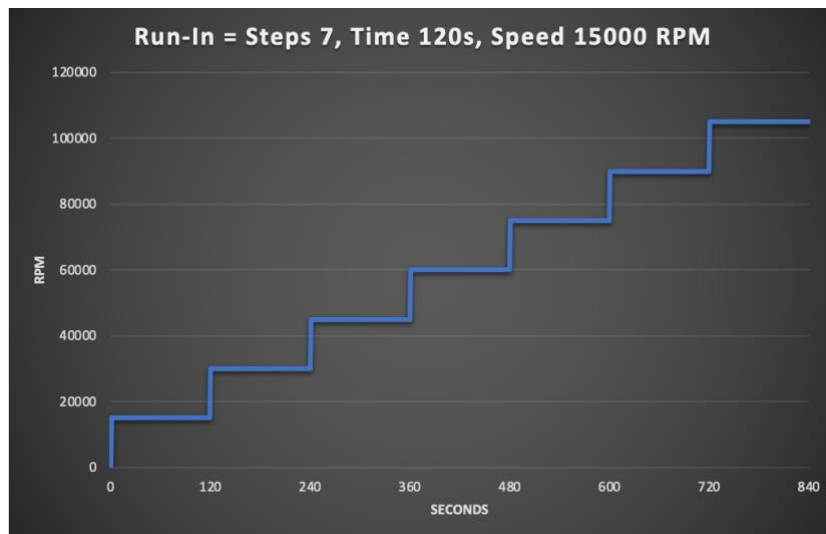

F. About page

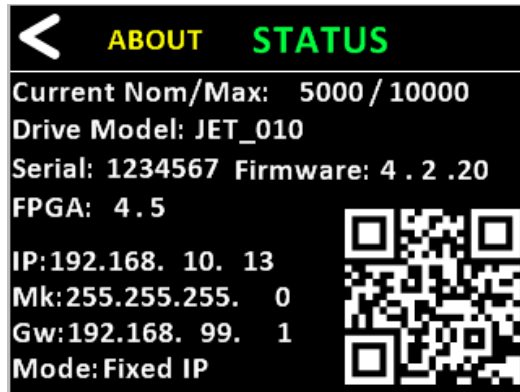

The about page reference all drive default information such as the nominal and max current in mA, the drive model, the serial number and firmware versions. It also features a quick access QR code that is directing the user to the manufacturer website and services.

When the ethernet connection option is present, the IP setting can also be found in this screen. Two connection mode exist, fixed IP, where the IP address is defined by parameters and DHCP, where the IP address is defined by the network DHCP master. This is only configurable by the ADM software.

XI. Motor start truth table with default settings

	Input	Function	State			
Control mode configuration	XIO 1 - MI_2	Internal set point selection	0	1	0	1
	XIO 1 - MI_3	External control selection	0	0	1	1
Control inputs	XIO 1 - ENA_1	Enable drive	1	1	1	1
	XIO 1 - ENA_2	Start/Stop	NC	NC	1	1
	HMI - Start stop button	Start/stop	1	1	NC	NC
	HMI - RPM slider	Speed control	NC	Set RPM	NC	Set RPM
	XIO 1 - Analog input	Speed control	Set RPM	NC	Set RPM	NC

1 = Activated, NC = State not considered.

Note: The control mode configuration is only considered at start-up or drive reset, changes made to the configuration require a drive reboot or a drive reset to be effective.

A. Minimum wiring with default configuration

Below is an example of the minimum wiring required to operate the drive as standalone with full HMI control (start/stop and speed selection).

1- [XIO 1](#)

Pin	I/O	Name	Meaning	Default function	Wiring
1	O	12V OUT	12 VDC supply voltage, limited to 100 mA		
2	I	A_IN -	Analog input -		
3	I	ENA_2	Enable 2 digital input	Start / Stop	
4	I	ENA_1	Enable 1 digital input	Enable drive	
5	I/O	GND	Ground		
6	O	MO_2	Multi. digital output 2	Non-Zero speed	
7	I/O	MCC	Digital Outputs common		
8	I	MI_1	Multi. digital Input 1		
9	I/O	GND	Ground		
10	I	A_IN +	Analog input +		
11	I	MI_3	Multi. digital Input 3	External control selection	
12	I	MI_4	Multi. digital Input 4	Reset	
13	O	MO_3	Multi. digital output 3	Speed reached	
14	O	MO_1	Multi. digital output 1	Drive operational	
15	I	MI_2	Multi. digital Input 2	Internal set point selection	

2- XSAFE

Pin	I/O	Name	Meaning	Wiring
1	I	STO_A	Safe torque off channel 1 +	
2	I	STO_B	Safe torque off channel 2 +	
3	I/O	GND	Ground	
4	O	REL_A	Relay contact A_ Normally open	
5	O	REL_B	Relay contact B_ Normally close	
6	O	20V OUT	18-22 VDC supply voltage, limited to 50 mA	
7	I	STO_A/	Safe torque off channel 1 -	
8	I	STO_B/	Safe torque off channel 2 -	
9	O	REL_C	Relay common	



Attention

NOT SAFETY RELEVANT!

XII. Error/Warning List – Troubleshooting guide

Error / Warning message	Description	Possible action(s)
ERROR - Over PWM	Maximum PWM duty cycle overpassed, the drive pulse width overpassed it's maximum.	Reset drive or power cycle
ERROR - Current Max	The maximum courant was overpassed	Reset drive or power cycle
ERROR - Current Max non reset	The maximum courant overpassed error is not reset	Reset drive or power cycle
ERROR - DC Bus	The internal DC Bus is not present	The drive might only be powered by it's auxiliary power supply or via USB, verify the main input voltage presence
ERROR - AC Input	AC Input not detected	Verify AC main supply
ERROR - Temp. Motor	The motor temperature have exceed the set limit	Let motor cool down, verify the load condition, verify electrical integrity. Reset drive or power cycle
ERROR - Temp. Drive	The drive temperature have exceed the set limit	Let the drive cool down, verify that sufficient ventilation is present. Reset drive or power cycle
ERROR - External Fault	An external fault was triggered on the drive logical entry	Reset drive or power cycle
ERROR - Motor Fault	The motor present a faulty condition	Verify electrical integrity. Reset drive or power cycle
ERROR - CMD not exec.	Command not executed	Internal drive fault, reset drive or power cycle
ERROR - STO active	The Safe Torque Off function is active meaning that the STO's entries are not powered.	Clear fault condition
ERROR - FPGA not Prog.	FPGA is not programmed	Internal drive fault, reset drive or power cycle
ERROR - I2T protection	The I2T protection occured, the current integrated in time have overpassed the set limit.	Reduce of verify the motor load condition, verify electrical integrity. Reset drive or power cycle
ERROR - Volt. Param not set	The internal DC bus is too low compare to the requested level	The drive might only be powered by it's auxiliary power supply or via USB, verify the main input voltage presence
ERROR - Soft-Hard not comp.	Hardware and software are not compatible.	Download compatible software to the drive, reset drive or power cycle
ERROR - No Resolver	Resolver not detected while the parameter set is calling for it	Verify the resolver connection
ERROR - No Encoder	Encoder not detected while the parameter set is calling for it	Verify the encoder connection
ERROR - Sensorless stall	The motor has stalled in sensorless mode	Verify motor load and motor integrity, Reset drive or power cycle, restart motor.
ERROR - Hardware problem	Hardware fault detected	Internal drive fault, reset drive or power cycle
ERROR - Main IRQ too long	Internal drive fault	Internal drive fault, reset drive or power cycle
ERROR - STO during enable	The Safe Torque Off function is active meaning that the STO's entries are not powered.	Clear fault condition, reset alarm.
ERROR - Corrupted Param.	Corrupted parameters	Internal drive fault, reload parameters, save, reset drive or power cycle
ERROR - Mot. Air sup. too low	The Motor Air Supply (MAS) is detected to low compared to the set threshold	Verify the motor air supply condition, clear fault condition

ERROR - Over power BUS	An over power on the internal DC bus have been detected	Reduce of verify the motor load condition, verify electrical integrity. Reset drive or power cycle
ERROR - Auto param. No code.	No code is read for the auto parameter detection, while the option is active. "0" is read.	Verify the motor connections. Verify parameter coding value in the connectors.
ERROR - No param for auto dtc.	The parameter set detected by the motor auto detection does not have a matching reference in memory	Verify the motor connections. Verify that you plugged a motor for which there is a parameter set loaded.
ERROR - Auto param. Mismatch	Their is a mismatch between the currently loaded parameter an the one detected on the motor connector.	If a motor change did occur, a drive reset in mandatory to load the new parameters. If not, verify the motor connection.
WARNING - Over PWM	Maximum PWM duty cycle reached, the drive pulse width is at it's maximum, current is limited by the couple motor/drive.	Warning state
WARNING - Mot. Temp.	The motor temperature have reach the set warning limit	Warning state. If the motor temperature keeps on rising, the error will occur
WARNING - Drive Temp.	The drive temperature have reach the set warning limit	Warning state. If the drive temperature keeps on rising, the error will occur
WARNING - Main IRQ too long	Internal dirve warning	Warning state
WARNING - Volt. not in param. WARNING - DC Bus not in range	The internal DC bus is too different compare to the requested parameter level	Warning state. The internal DC bus may have change or the choosen parameter set is not adapted to the DC bus voltage level
WARNING - Resolver sat.	The resolver input is saturated	Verify the resolver connection, adapt the amplitude compensation parameter
WARNING - Limit switch active	One of the limit switch is activated, forbiding the motor rotation in one direction.	Remove warning condition
WARNING - I2T Drive	The I2T protection is at warning level, the current integrated in time have overpassed the set limit.	Reduce of verify the motor load condition, verify electrical integrity
WARNING - I2T Motor	The I2T protection is at warning level, the current integrated in time have overpassed the set limit.	Reduce of verify the motor load condition, verify electrical integrity
WARNING - Eth. link no connect	Ethernet link is not connected	Verify the connection parameters and the physical ethernet connection

XIII. ADM – Drive Manager Software

The ADM functionalities are described in another manual, please contact us for details.